

MANHATTAN



IPE



TEAK



LIGHT GREY



DARK GREY



CEDAR



Cobra Start/End
(30 clips + 30 screws)



Cobra Hybrid 8-18
(90 clips + screws)
1 bag for 4.5 m² (138mm)

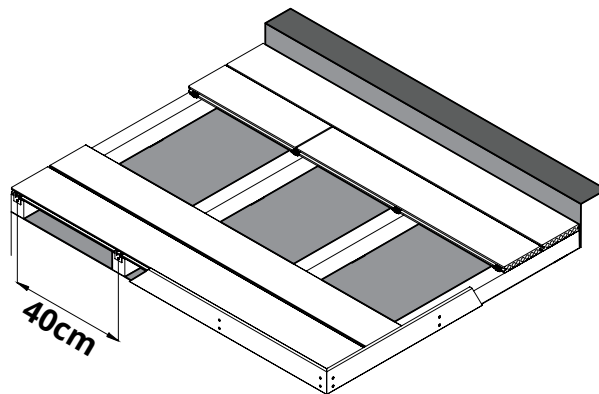

MANHATTAN

PROPERTY	TEST METHOD	TEST RESULTS	NOTES / REQUIREMENTS
Composition	-	HDPE = 30 % Wood powder = 60 % Additives = 10 %	-
Density	EN 15534-1	1.27 g/cm ³	-
Linear mass	EN 15534-1	3.9 Kg/m	-
Deviation from Straightness	EN 15534-1	≤ 1 mm / metre	-
Cupping	EN 15534-1	≤ 0.5 mm	-
Maximum load	EN 15534-1	3500 N	Span : 400 mm F _{max} ≥ 3 300 N (EN 15534-4)
Deflection at 500 N	EN 15534-1	2.04 mm	Span : 400 mm ≤ 2.5 mm (EN 15534-4)
Modulus of elasticity	EN 15534-1. Annex A	2700 MPa	Span : 400 mm Bending test on finished product at normal condition 20°C and 65% RH
Bending strength	EN 15534-1. Annex A	29 MPa	
Resistance to indentation (Brinell Hardness)	EN 15534-1	Brinell hardness : 79 MPa Rate of elastic recovery : 2.27 %	Applied load : 2000 N
Resistance to artificial weathering	EN 15534-1	ΔE = 1	2000 hours. ISO 4892-2 cycle 1
Swelling and water absorption (28 days)	EN 15534-1 EN 317	Swelling: 0.5 % in thickness 0.16 % in width 0.18 % in length Water absorption in weight : 0.28 %	Swelling: ≤ 4 % in thickness ≤ 0.8 % in width ≤ 0.4 % in length (EN 15534-4) Water absorption in weight ≤ 7 % (EN 15534-4)
Boiling test	EN 15534-1 EN 1087-1	Water absorption in weight = 0.27 %	Water absorption in weight ≤ 7 % (EN 15534-4)
Falling mass impact resistance	EN 15534-1	No crack	Striker weight : 1000 ± 5 g Falling distance : 700 ± 5 mm No cracks on 10 test specimens. (EN 15534-4)
Heat reversion	EN 15534-1 EN 479	0.01 %	100°C - 1 hour